

NERGECO C FREEZER 2



TECHNICAL DATA

MAXIMUM SIZE

3.500 mm W x 4.500 mm H

SPEED (standard door, depending on curtain dimensions)

Opening: up to 0.8 m/s
Closing: up to 0.8 m/s

CURTAIN

670 g/m² PVC
Insulating triple-skin curtain with integrated double PU foam (U = 1,97 W/m².K)
Stiffeners every 620 mm

STRUCTURE

Self-Supporting Steel Structure in 3 mm thick structural multifold steel shape, treated with a PP primer and a PU coloured finish.
Vertical side guides with low-diffusion and self-regulated heating

ENGINE

Three-phase engine from 1,1 to 2,2 kW (depending on size and selected options) with heated brake and deep-freeze grade lubrication
Transom opening from front, optional from top.

CONTROL BOX

Crouzet PLC logic control
Distance panel up to 2 m, optionally longer
IP66 control box Polyester 500 x 400 mm
Optional box 500 x 400 in steel IP66 or stainless steel IP67

SAFETY

Intelligent Curtain® with spiral cable and 3 sets transversal photocells, MOFT/MOFR IP67 at 280 mmH
Optional without Intelligent Curtain®:
Inside EU: 4 sets of photocells - speed 0,5 m/s
Outside EU: 2 sets of photocells - speed 0,8 m/s

POWERLESS OPENING

Ratchet
Optional: Inverter + UPS

ACTIVATORS

Push buttons (option wireless) - pull cords (option wireless or on bracket) - radar - radio transmitter/receiver - induction loop - detection photocells

POWER

400V three-phase - 50 Hz - differential circuit breaker 300 mA
Optional: 230V three-phase - 50Hz / 230V single-phase - 50 Hz (with frequency drive) / 440V three-phase / 60 HZ frequency

CURTAIN COLOURS (similar to - colour sample on demand)

Food-Grade Colours

	WHITE RAL 9010
	BEIGE RAL 1014
	LIGHT BLUE RAL 5015
	LIGHT GREEN RAL 6018

Non Food-Grade Colours

	DARK BLUE RAL 5010
	DARK GREEN RAL 6026

STRUCTURE COLOUR

	DARK BLUE RAL 5010		BEIGE RAL 1014
	DARK GREEN RAL 6026		LIGHT BLUE RAL 5015
	WHITE RAL 9010		LIGHT GREEN RAL 6018

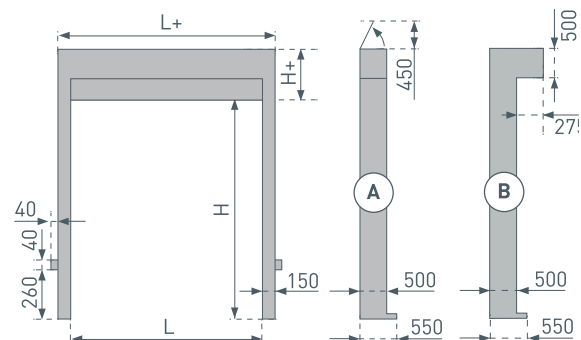

LAYOUT DIMENSIONS

A. With option motor canopy opening on the top

H or L	1.500	2.000	2.500	3.000	3.500	4.000	4.500
L+	1.800	2.300	2.800	3.300	3.800	-	-
H+	1.090	1.170	1.250	1.330	1.410	1.490	1.570

B. With option motor canopy opening on the front

H or L	1.500	2.000	2.500	3.000	3.500	4.000	4.500
L+	1.800	2.300	2.800	3.300	3.800	-	-
H+	880	960	1.040	1.120	1.200	1.280	1.360

© Entrematic Group AB – 2018

Entrematic offers a comprehensive range of products for industrial, commercial, institutional and residential applications, including sectional doors, loading dock equipment, high-performance doors, residential garage doors, pedestrian doors, gates and barriers, and automation and operators. Built on nearly 200 years of accumulated expertise, Entrematic aims to be the most dynamic, innovative company in the entrance automation industry, and the best partner for dealers and installers. Our well-known brands include Normstahl, Dynaco, Ditec, EM and Nergeco.

Entrematic, Amarr, Kelly, Serco, Normstahl, Dynaco, Ditec, EM and Nergeco, as words and logotypes, are examples of trademarks owned by Entrematic Group AB or companies within the Entrematic Group.

The Nergeco products are protected by worldwide registered patents. As part of its policy of continuous product development, Entrematic Group NV reserves the right to change the characteristics of its products or components without prior notice.

Disclaimers:

For a correct use of our products, please refer to our manual. Everything that is mentioned in this brochure is only valid under the terms of use in the user manual and on condition that the door was properly installed and maintained and has not undergone abuse nor neglect.

NERGECO DEALER



ENTRE/MATIC BELGIUM NV
Waverstraat 21
B-9310 Moorsel-Aalst (Belgium)
Tel. +32 53 72 98 98
Fax. +32 53 72 98 50
info.nergeco.eu@entrematic.com
www.nergeco.com

