

CORRECT DOOR HEIGHT

TO ALLOW DOUBLE REAR DOORS TO OPEN INTO AND OVER DOCK
And Docking Bay Door Opening

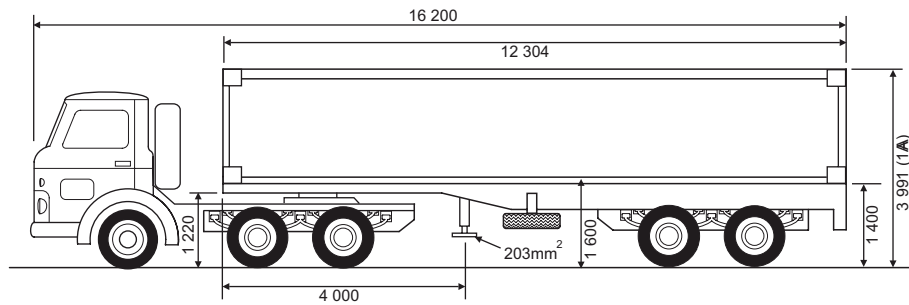

12m Skeletal Semi-trailer

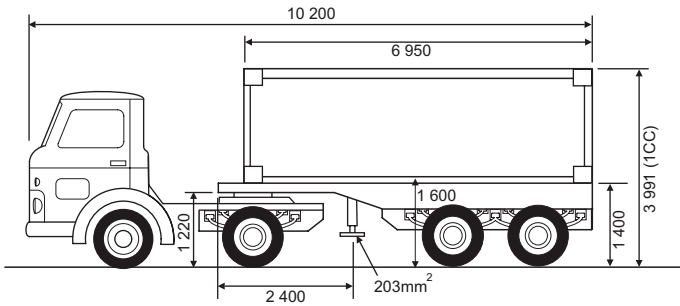

6m Skeletal Semi-trailer

	6 Metre (20)	12 Metre (40)
Hauler	2 Axles	3 Axles
Capacity in containers	1 x 6m (20)	1 x 12m (40)
Overall length of trailer	6 950mm	12 304mm
Maximum width	2 500mm	2 500mm
Unladen height from ground level to top of container	3 991mm	3 991mm
Unladen height from ground level to top face of twist lock	1 400mm	1 400mm
Downward deflection with load	65mm	65mm
Combined length	10 200mm	16 200mm
Distance from front of trailer to landing legs	2 400mm	4 000mm
Tare of trailer (approx)	3 250kg	5 850kg
Maximum payload	20 320kg	30 480kg
Turning circle	8 000mm	11 000mm
Parking area (herring or diagonal system) (approx)	150/ha	100/ha
Landing leg base dimensions	203mm ²	203mm ²

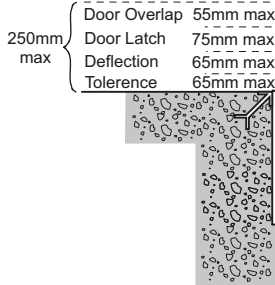
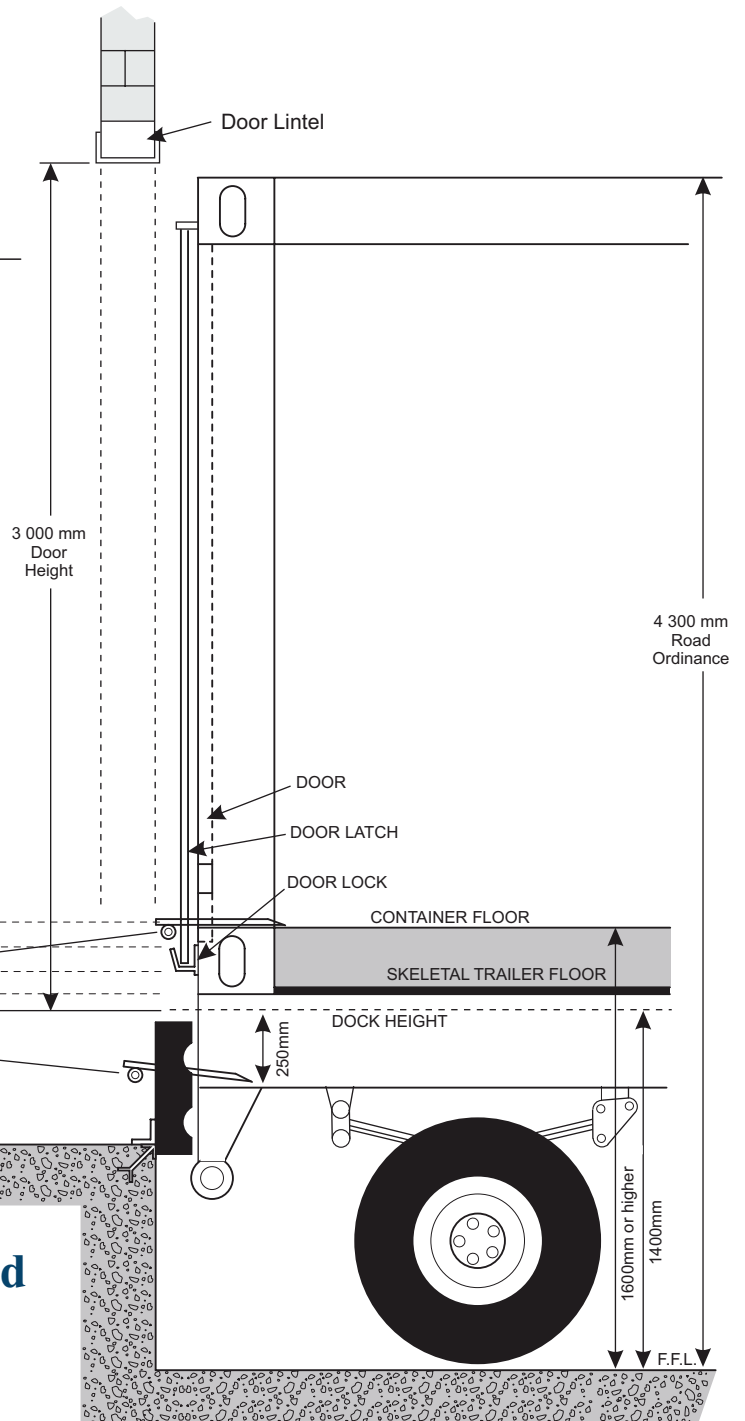

DDL Equipment Pty Ltd

Reg No: 2005/043409/07

E-Mail: sales@ddl.co.za

Website: www.ddl.co.za

Tel: 011 393 1209

Fax: 011 393 1169

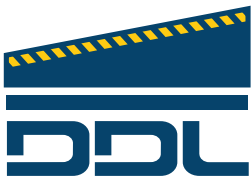

TIME TESTED DOCKING

6 Neutron Road, Chloorkop, Kempton Park

F.F.L. - Finished Floor Level

Ref: SEC-D.2