

# DOCK CUBICLE

## Free Standing Steel Base Unit

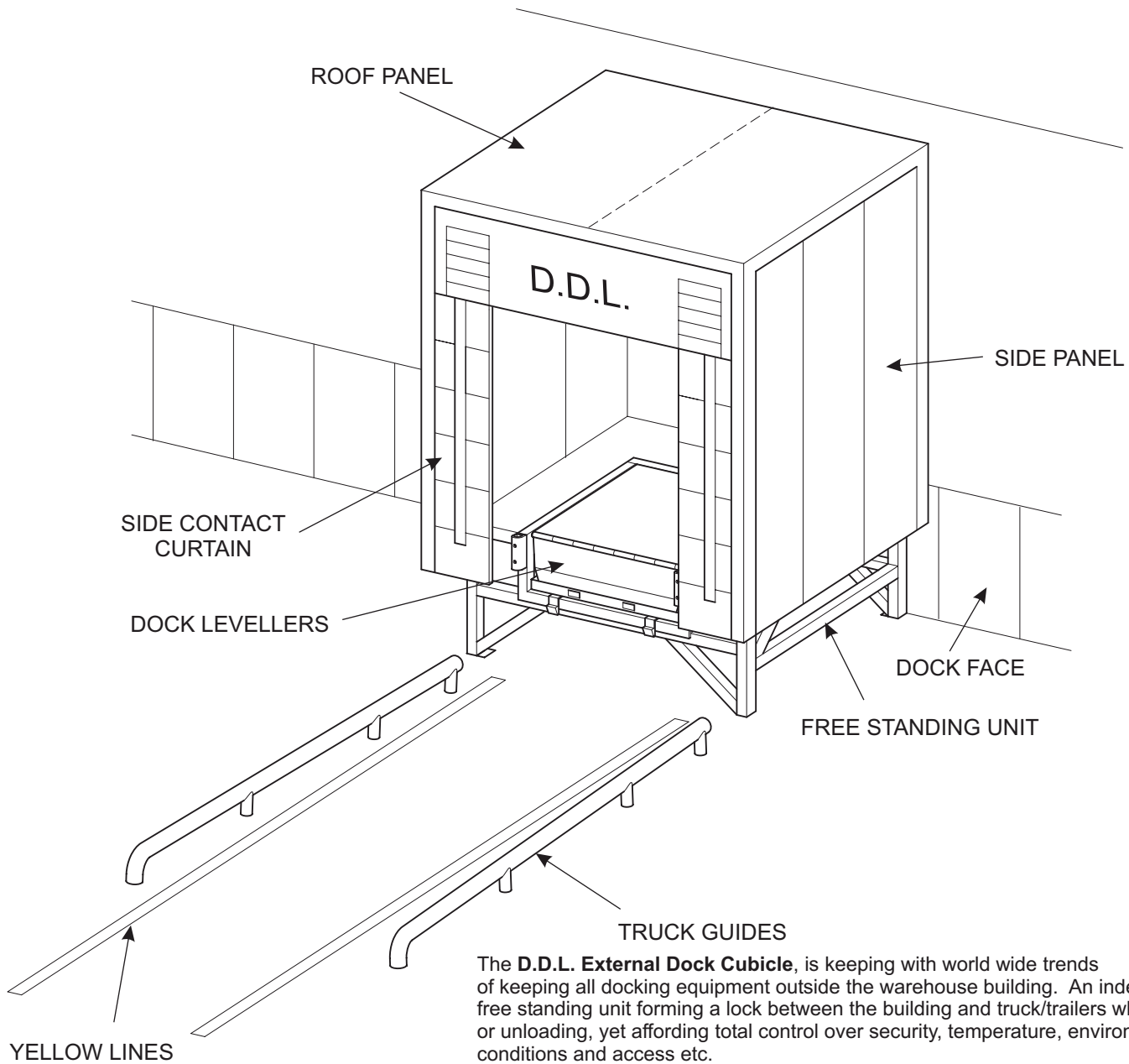

The **D.D.L. External Dock Cubicle**, is keeping with world wide trends of keeping all docking equipment outside the warehouse building. An independent free standing unit forming a lock between the building and truck/trailers while loading or unloading, yet affording total control over security, temperature, environmental conditions and access etc.

The **Dock Cubicle** is ideally suited as an add-on, for existing completed buildings.

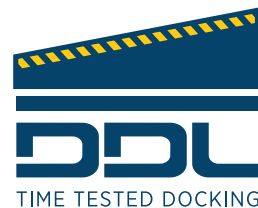

### DDL Equipment Pty Ltd

Reg No: 2005/043409/07

E-Mail: [sales@ddl.co.za](mailto:sales@ddl.co.za)

Website: [www.ddl.co.za](http://www.ddl.co.za)

Tel: 011 393 1209

Fax: 011 393 1169

6 Neutron Road, Chloorkop, Kempton Park

Ref: DSS.10

**MODEL  
36/750**

**MODEL  
33/650**

		MODEL 36/750	MODEL 33/650
OH	- Overall Height	mm	mm
OW	- Overall Width	mm	mm
IW	- Internal Width	mm	mm
OL	- Overall Length	mm	mm
OHL	- Overhang Length	mm	mm
CD	- Curtain Drop	mm	mm
SCW	- Side Curtain Width	mm	mm
DH	- Dock Height	mm	mm
DLOW	- Daylight Opening Width	mm	mm
DLOH	- Daylight Opening Height	mm	mm