

APPLICATIONS UNLIMITED

LIFT TABLE & ELEVATING DOCK

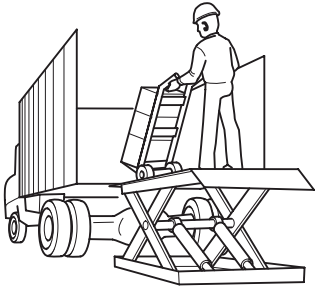

Truck Loading

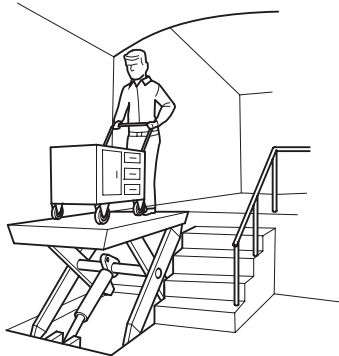

Split Level Floor Transfer

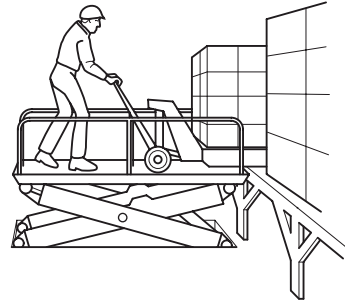

Loads to Mezzanines and Stagings

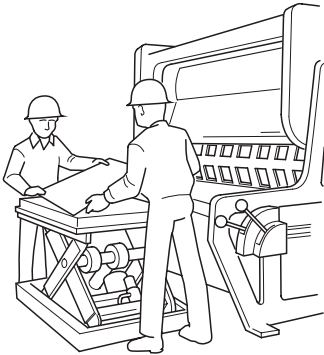

Feeding Stock to Machines

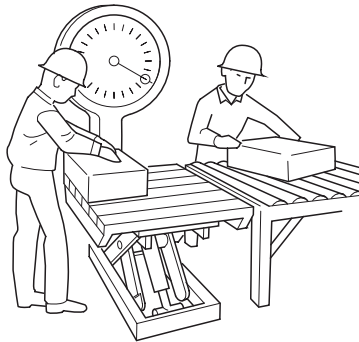

Load Skids and Weighing

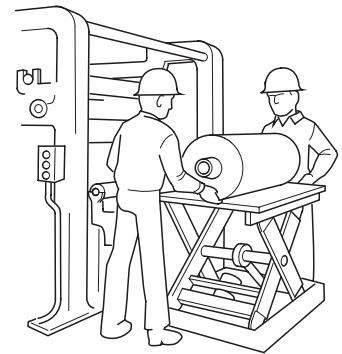

Positioning Large Rolls

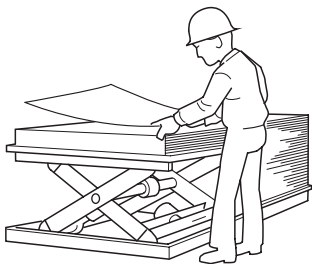

Counting and Inspection

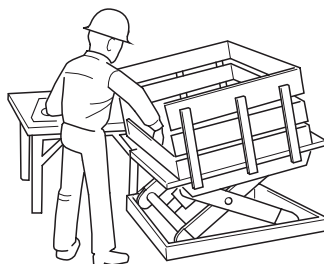

Tilt Top Model Speeds Production

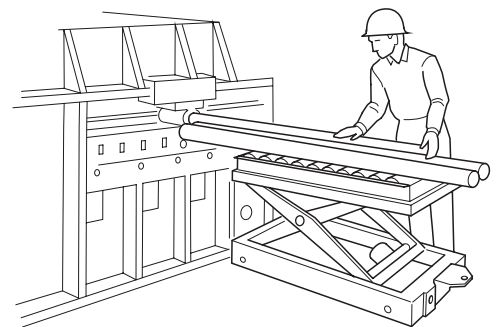

Roller Top Feeding for Cut-off Operations

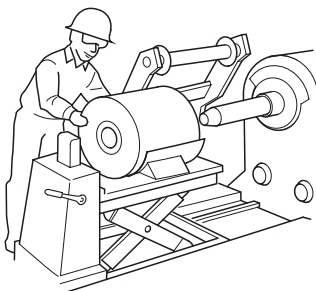

Transferring Coils

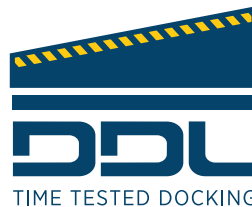

DDL Equipment Pty Ltd

Reg No: 2005/043409/07

E-Mail: sales@ddl.co.za

Website: www.ddl.co.za

Tel: 011 393 1209

Fax: 011 393 1169

6 Neutron Road, Chloorkop, Kempton Park

Ref: AP.1-LT