

ELEVATING GOODS LIFT

WELL / SHAFT DESIGN OPTIONS

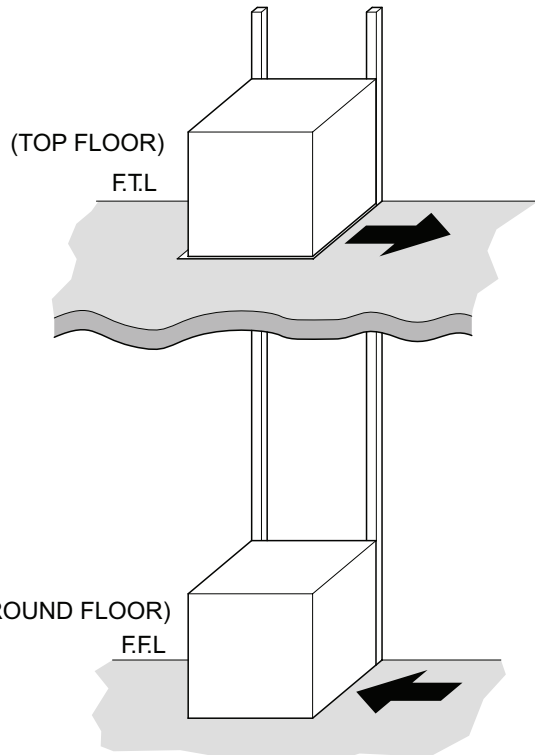

ONE SIDE
ENTRANCE/EXIT

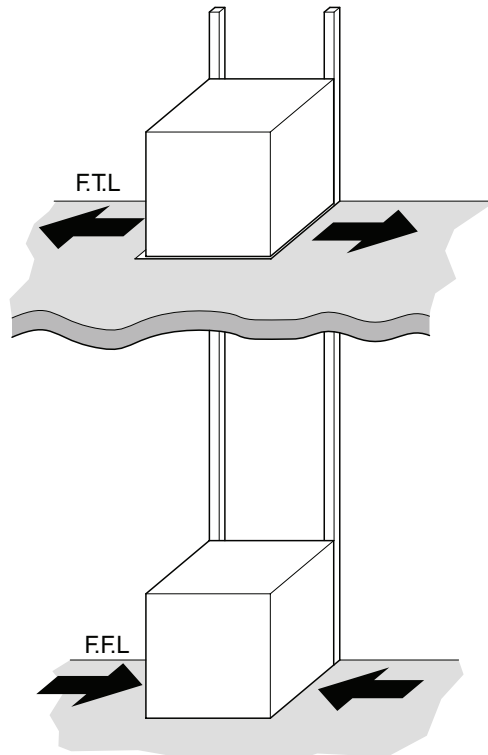

TWO SIDE
ENTRANCE/EXIT

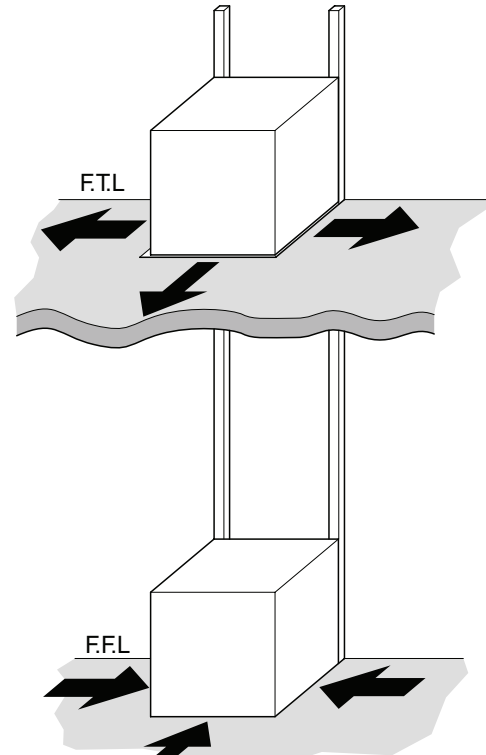

THREE SIDE
ENTRANCE/EXIT

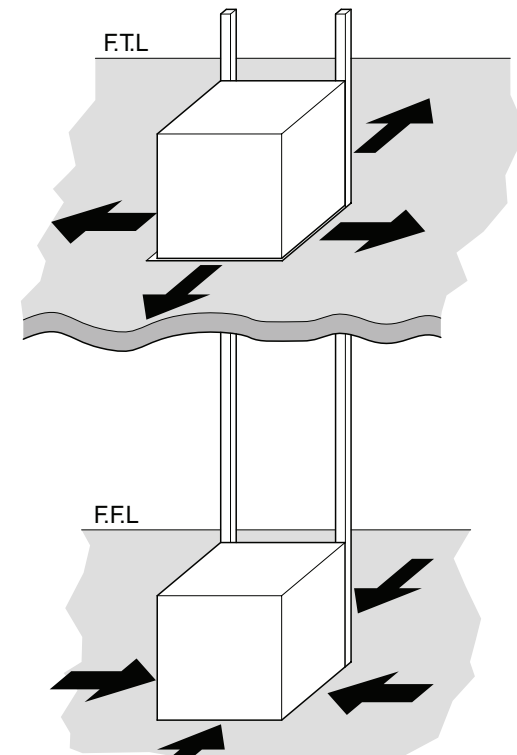

FOUR SIDE
ENTRANCE/EXIT

Well / Shaft Surround Construction

- Solid Brick
- or
- Brick and Steel

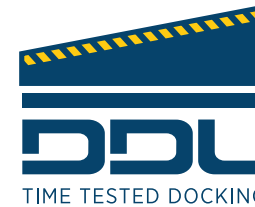

DDL Equipment Pty Ltd

Reg No: 2005/043409/07

E-Mail: sales@ddl.co.za

Website: www.ddl.co.za

Tel: 011 393 1209

Fax: 011 393 1169

6 Neutron Road, Chloorkop, Kempton Park