

# A FAST OPENING SINGLE DOOR WITH ELECTRIC MOTOR

Fig 6

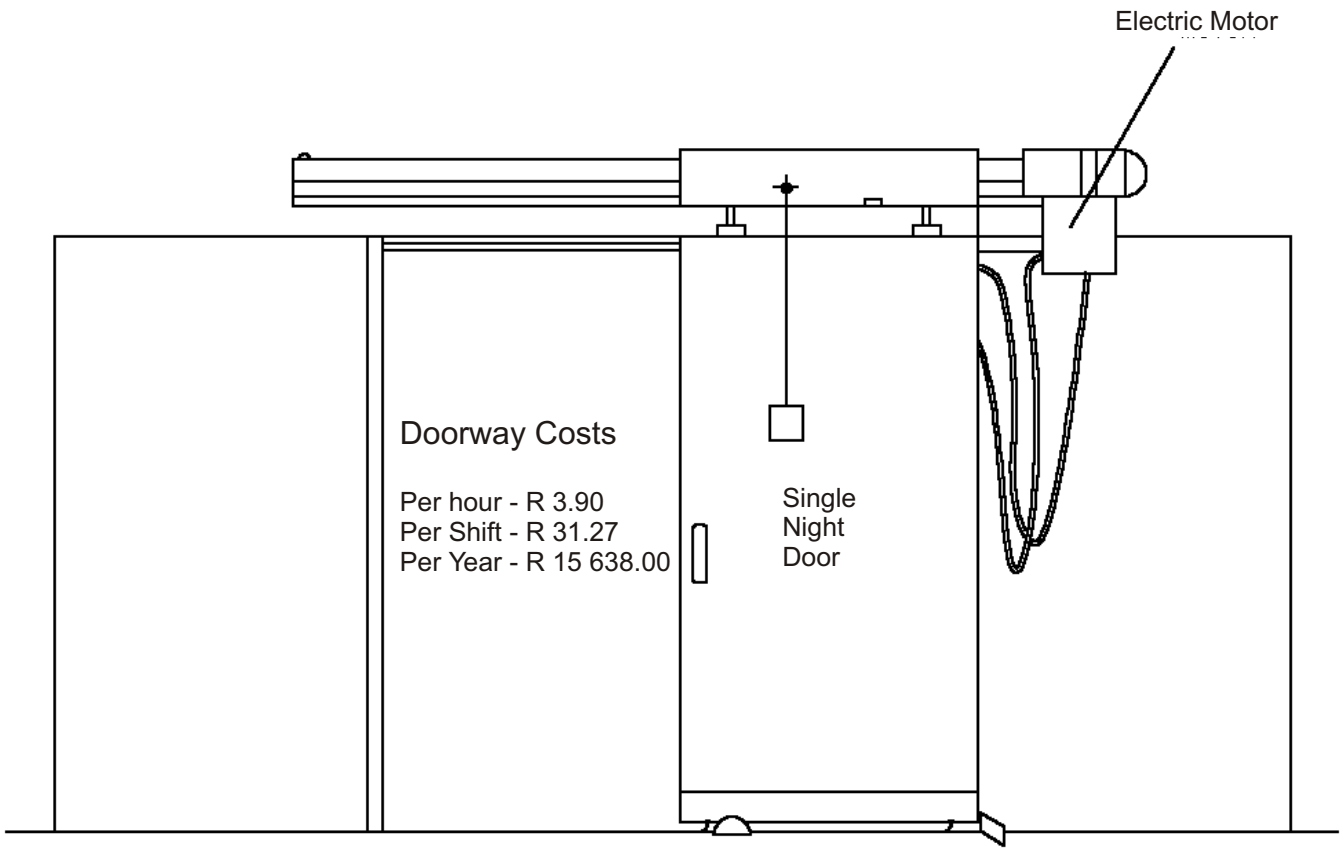

MEMBER OF  
SOUTHERN AFRICAN REFRIGERATED  
DISTRIBUTION ASSOCIATION



**D.D.L. EQUIPMENT cc**

P.O. Box 210, Strathavon, 2031

Tel : +27 11 443-4233

Fax : +27 11 882-4569

E-Mail : [ddl@icon.co.za](mailto:ddl@icon.co.za)

Web Site: [www.ddl.co.za](http://www.ddl.co.za)

Cell : 083 653 3872

*"The Bridge That Links The Total Materials Handling Systems Together"*

**Ref: HSD.8 - CIG**