

# MARK II

# A Total Balanced Dock Leveller

## VARIOUS TOP DECK POSITIONS

- Two (2) - Hydraulic Cylinders
- Swing Lip Cylinder
- Deck Lift Cylinder

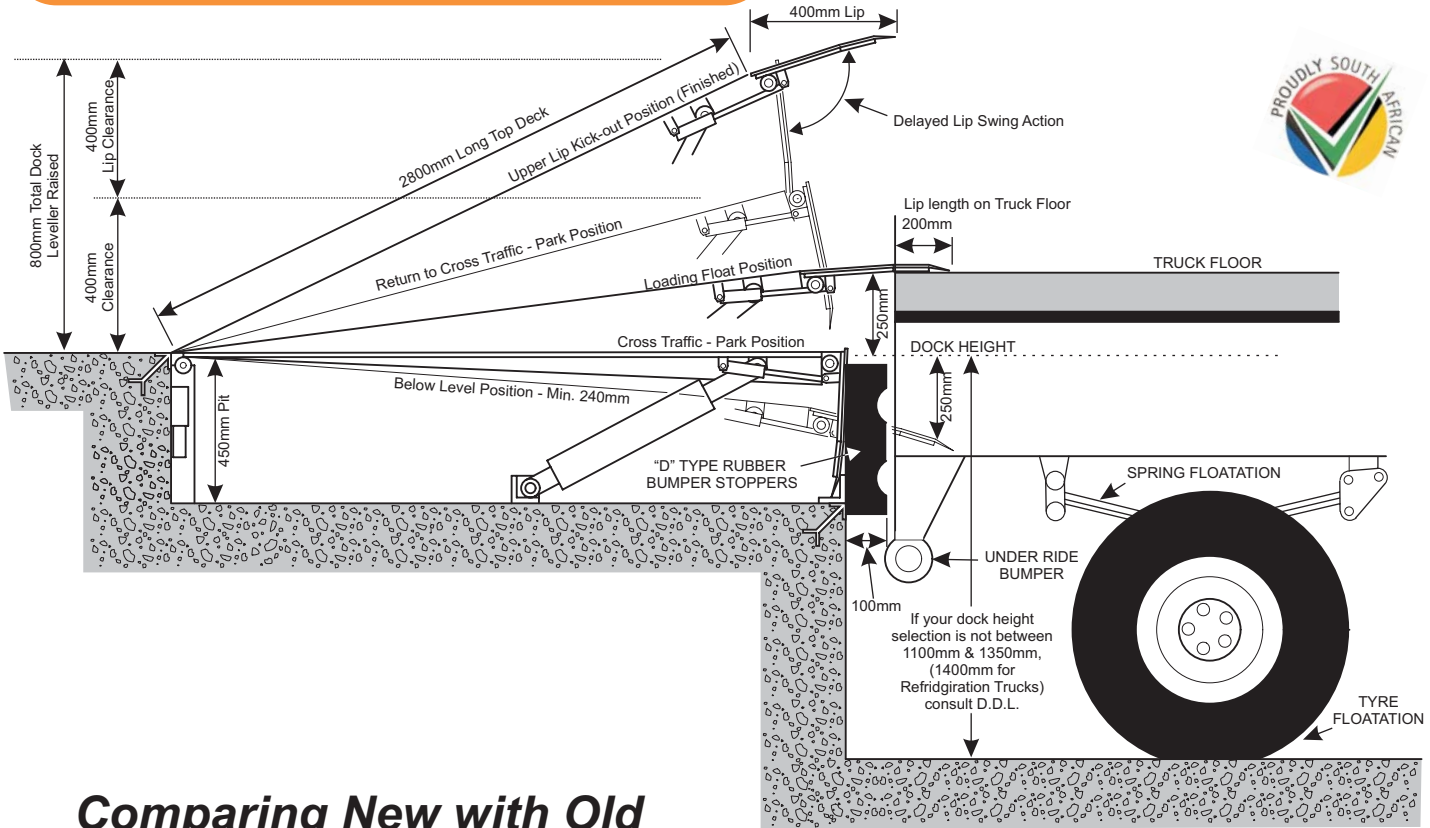

### Comparing New with Old

## CONVENTIONAL MECHANICAL LIP ACTION CAM TYPE SWING LIP ACTIVATED

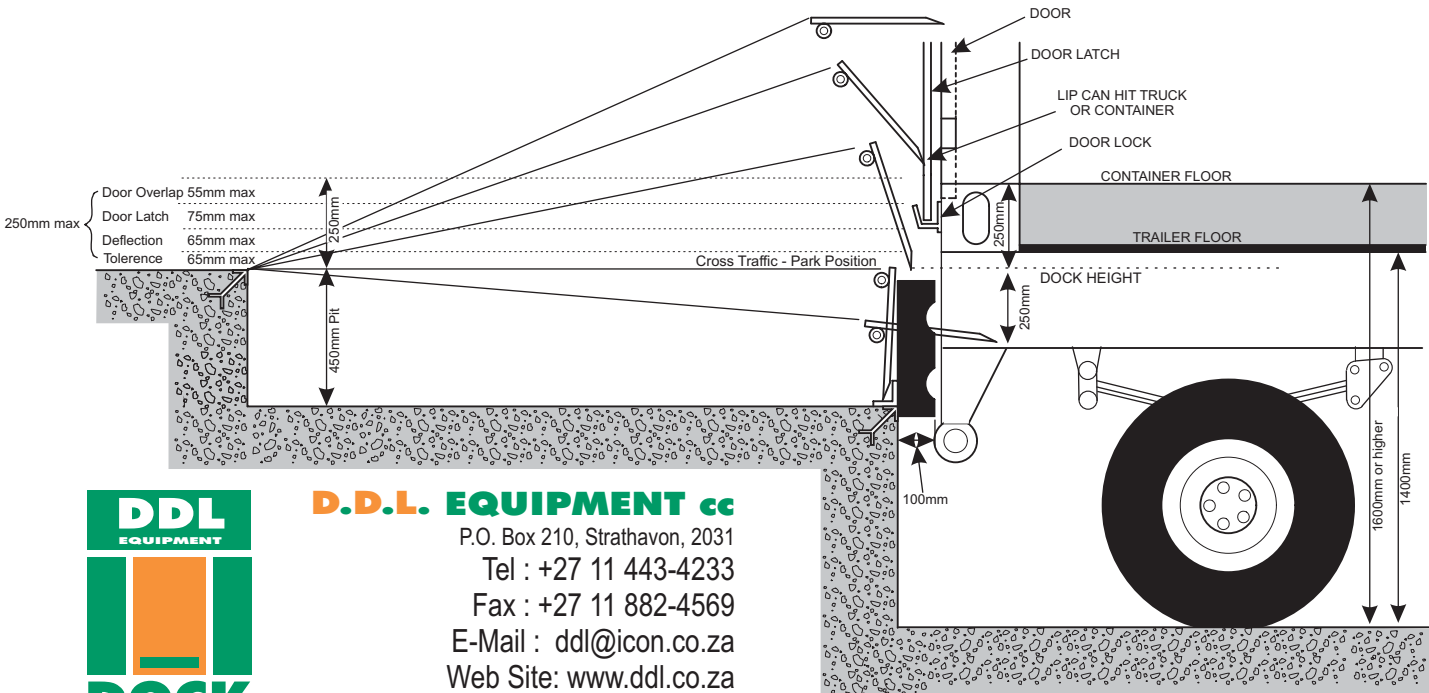

**D.D.L. EQUIPMENT cc**  
 P.O. Box 210, Strathavon, 2031  
 Tel : +27 11 443-4233  
 Fax : +27 11 882-4569  
 E-Mail : ddl@icon.co.za  
 Web Site: www.ddl.co.za  
 Cell : 083 653 3872

"The Bridge That Links The Total Materials Handling Systems Together"

Ref: DE.33