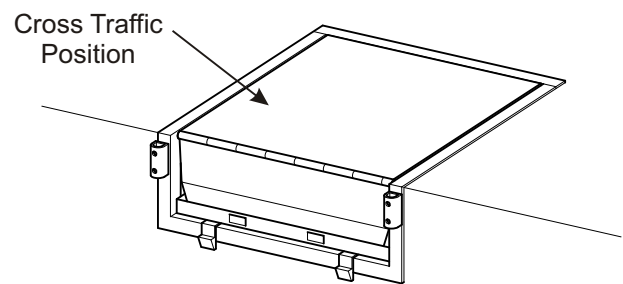

**FIGURE 13**

11. On electrical models, mount the control box next to the isolator switch.

Make permanent electrical or hydraulic connections.

Remove the brace and lower the deck to the "Cross Traffic" position. (See Figure 13 and 14)



**FIGURE 14**

12. To raise and lower the deck use the push button controls on the EHP Model. (See Figure 15a)

Mount HHP model pump unit to the floor with concrete bolts, close to the PVC pipe in the floor.

Position of HHP pump must out of the way of traffic.

Raise and lower the deck using the up/down hand control on the HHP Model. (See Figure 15b)

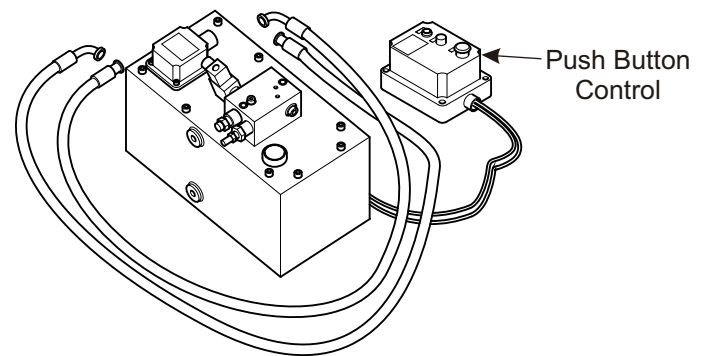

**FIGURE 15a**

13. Stand - By Hand Pump (See Figure 15c)

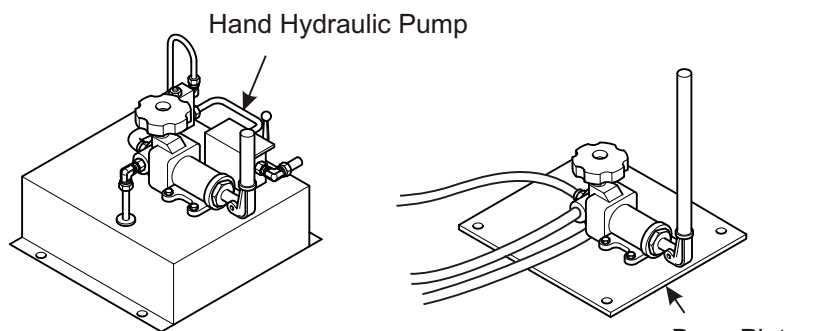

**FIGURE 15b**

**FIGURE 15c**