

8. Set the Upper Deck by letting the platform move up and down three times so it can settle. (See Figure 8)

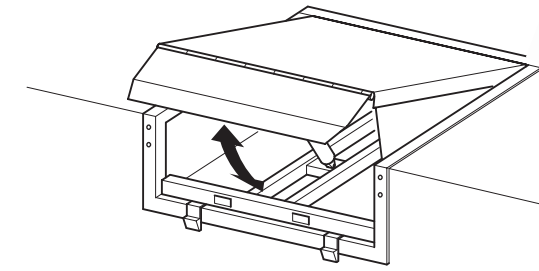

FIGURE 8

9. Spot, space or butt weld the dock leveller rear frame to the pit frame in five (5) places. (See Figure 9)

Consideration must be given to the condition of the curb angles, concrete, etc. An alternative is to use a steel bridge plate as shown in Figure 11.

- Weld all shims to the dock leveller frame.
- Weld front of dock leveller frame to safety stops.
- Weld safety stops to the pit frame.

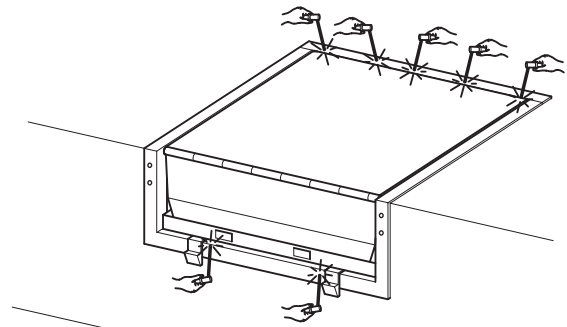

FIGURE 9

**Note:**

Spot, space or butt weld as the dock leveller is not a fixture. The equipment can be removed in the event of moving to other premises, or for service, retrofit, or replacement.

**FREE STANDING MODELS**

10. Assemble free standing unit.

Level the unit making certain the top of the deck is flush with the dock. (See Figure 10)

Weld unit to angle on loading bay.

If the dock leveller is secured at the rear using a bridge plate as in Figure 11, shim unit to be flush with the bridge plate.

Bolt the free standing unit down with concrete bolts.

Grout under legs.

Lift dock leveller with fork lift truck using front pockets, or use a sling in the front pockets and rear frame.

Butt the dock leveller against the dock wall. (See Figure 12)

Weld dock leveller to angle on loading bay and to the front of the free standing unit. (See Figure 9)

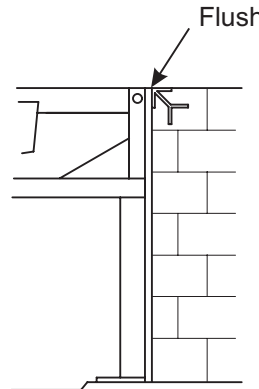

FIGURE 10

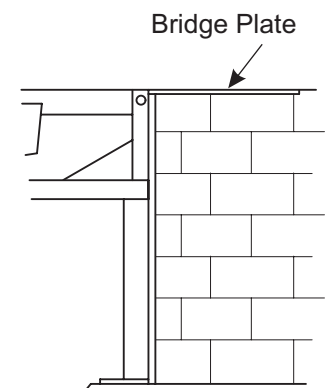

FIGURE 11

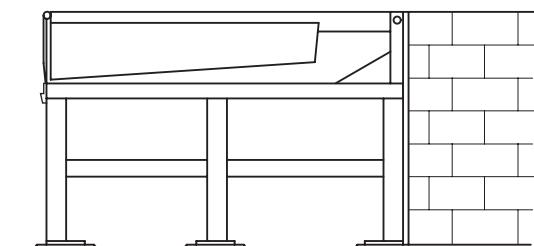

FIGURE 12