

WARNING
DO NOT WORK BENEATH LEVELER WITHOUT BRACING THE DECK AND DISCONNECTING THE ELECTRICAL SUPPLY

- After leveller is placed in the pit, raise the deck and securely brace it in its fully raised position. (See Figure 4)

On hydraulic models the deck can be raised manually (using lifting equipment) or temporary electrical or hydraulic hookup can be made.

In the latter case make certain the motor electrical cable or hose will be accessible after the dock leveller has been lowered into place. On pit models with "remote" pushbutton control, the pushbutton unit is stored under the deck during shipping.

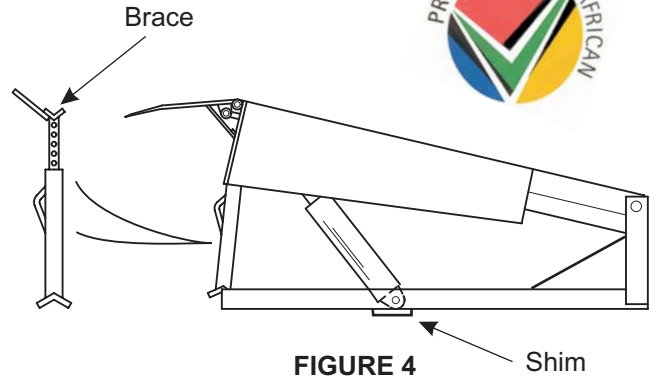

- Feed the electrical cable through the PVC pipe cast in the concrete floor, so that the leveller can be tested and operated when its in place. (See Figure 5).

Make any further shim adjustments to make the dock leveller flush with the finished floor, especially at the rear. Make sure the unit is centered and square in the pit and as far back as possible.

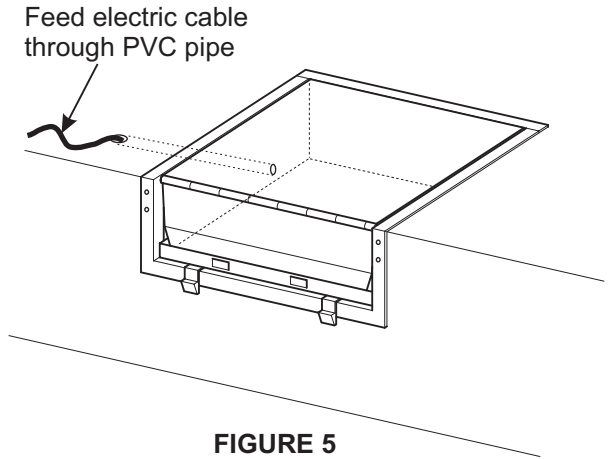

- The back of the safety stops should be in line with the front of the dock leveller frame. Shim between safety stops and frame if necessary. Shims at the front must not extend beyond the dock leveller frame. (See Figure 6)

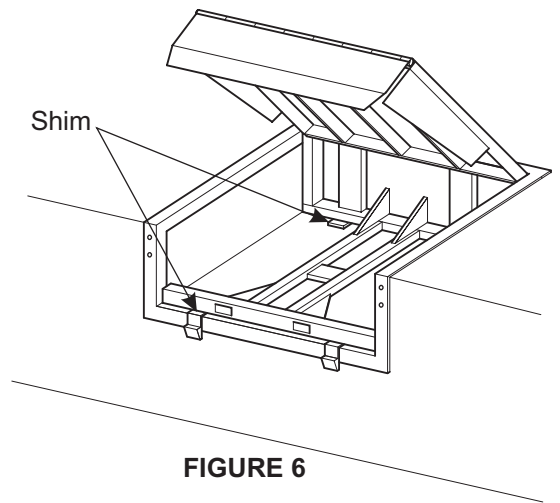

- Shim under cross member at the rear of the cylinder until the cross member is supported. (See Figure 6 and 7)

