

# DDL MARK II LEVELERS

## INSTALLATION INSTRUCTIONS



### MEASURING (Pit Inspection)

1. Pits built for the installation of dock levellers must be checked for accurate measurements and squareness in advance. Diagonal difference may not be more than 15mm. Check the position of the cable/PVC pipe. (See Figure 1)

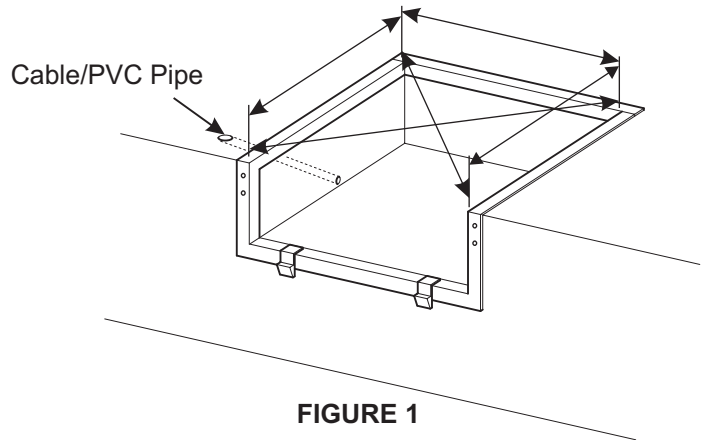

FIGURE 1

### PIT INSTALLED MODEL

2. Place shim at all four corners of the pit. Shim as required so the top of the deck in the cross traffic position will be flush with finished floor.

Remove safety stops from the front of the dock leveller. Place the safety stops over the front pit angle. (See Figure 2)

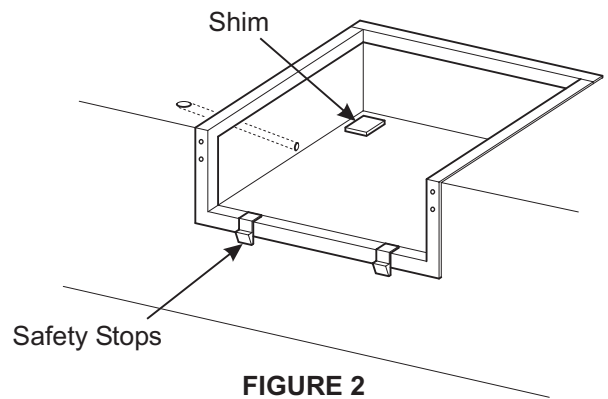

FIGURE 2

3. Lift the dock leveller with fork lift truck using front pockets, or with a crane use a sling in the front and rear pockets.

Lower the dock leveller into the pit keeping it as close to the rear of the pit as possible. (See Figure 3a, 3b and 3c)

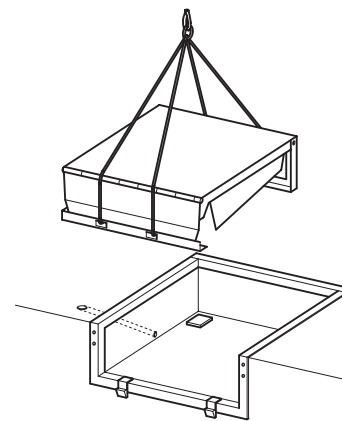

FIGURE 3b  
Via Overhead Crane

#### Lifting via:

- Front End Loader
- Overhead Crane
- Mobile Crane

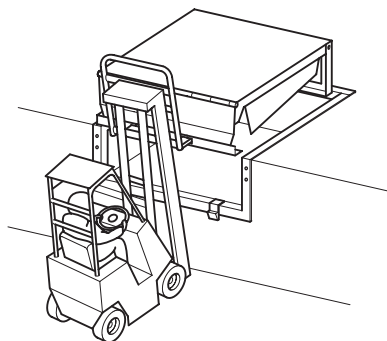

FIGURE 3a  
Via Forklift

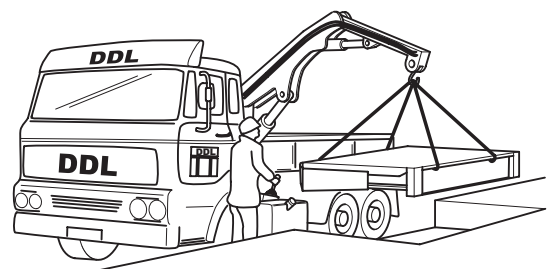

FIGURE 3c  
Via Mobile Crane