

Docking - an important, integrated part in the logistic process

With 50 years of experience and more than 200,000 loading bay installations worldwide, Crawford is Europe's leading supplier of docking systems. We are able to help you find the solution most suitable to your need.

A docking system is part of comprehensive logistic process, which in turn puts high demands on the products facilitating it. Making the optimal decision at an early stage will contribute to considerable cost savings for the user. Our experts can help you to specify the optimal solution for your particular needs.

The different modules of our Docking System contributes to efficient handling of goods and a safe and comfortable working environment.

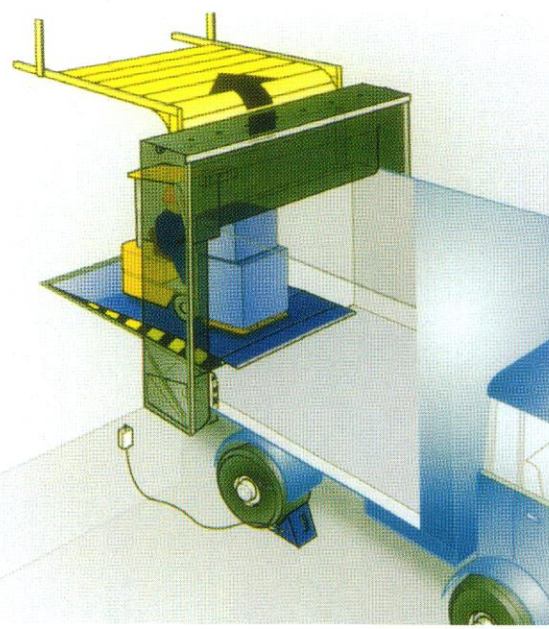

Dock leveller - bridges the distance between vehicle and bay, thus eliminating the difference between truck bed and floor.

Dock sealing systems - tightens around the vehicle and eliminates draughts, rain, pilferidge, birds, insects and dust.

Cubicle - optimises floor area utilisation by permitting loading and unloading outside the building.

Industrial door - Crawford 542 logistic- seals off the building, giving protection and energy savings.

- Cubicle
- Dock Leveller
- Dock Sealing Systems
- Dock Logistic Doors
- Dock Bumpers
- Wheel Chocks
- Truck Guides
- Docking Bay Lights

Crawford is able to meet the demands of all potential customers, from small sized companies with only one or a few loading bays to central warehouses with more than 100 loading bays and a non-stop 24-hour operation.

