

PIT FRAME

Lift Table and Stationary Elevating Dock Pit Dimensions

Customer _____			
Model _____	Job _____	Serial _____	P.O. No _____
Power & Control Arrangement _____		Lip Recess(es) _____	Side(s) _____
Approved for Construction _____		Date _____	

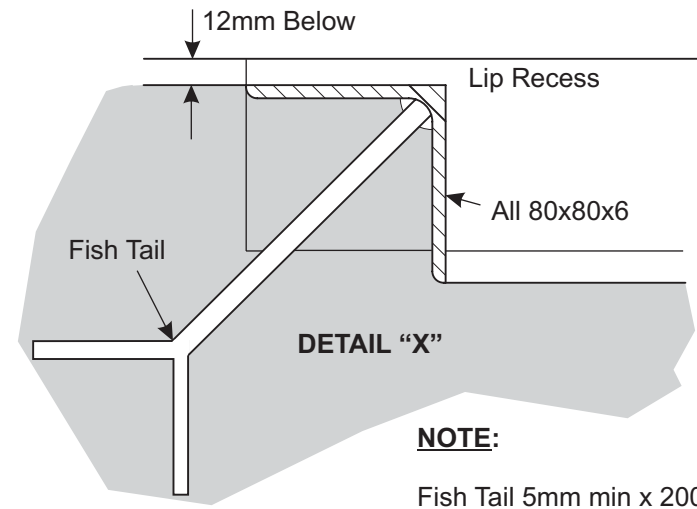
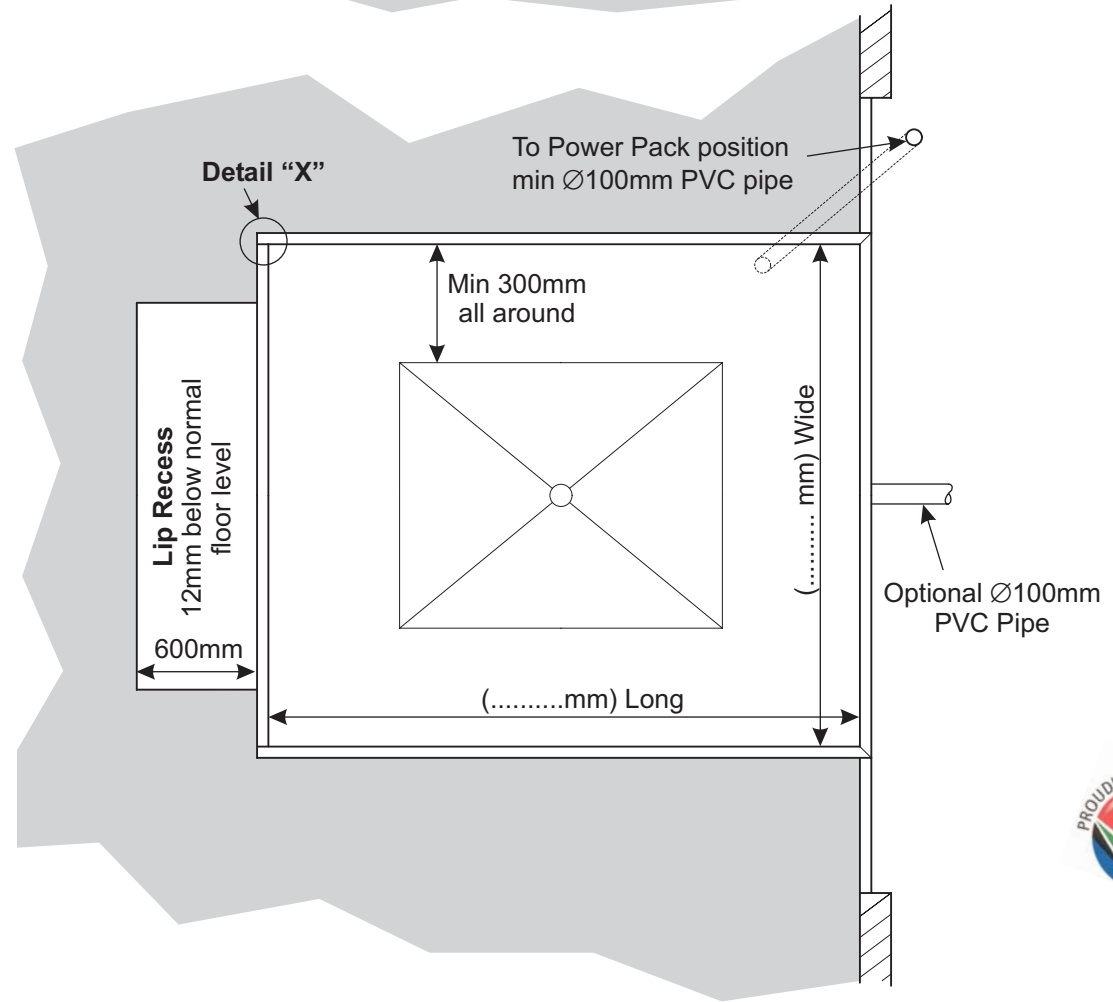
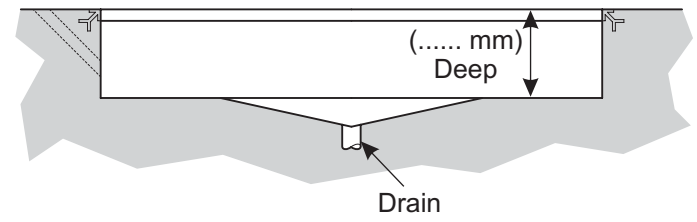
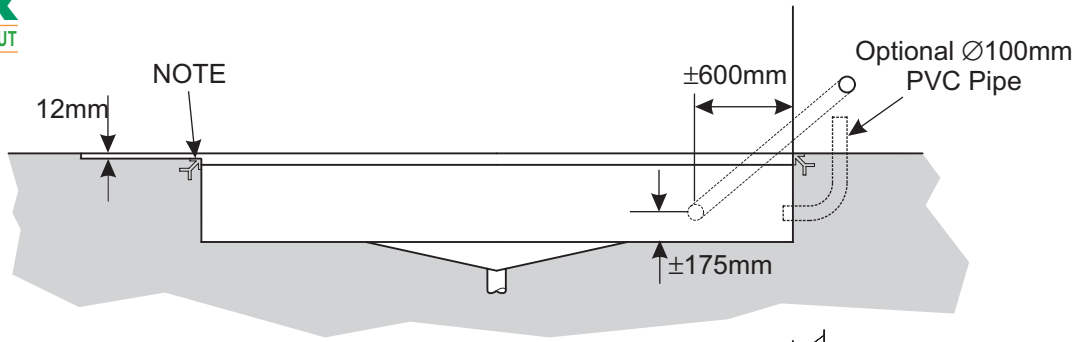

NOTE:
Fish Tail 5mm min x 200mm long
at 500mm Pitch max

Ref: AP.6-ED

